

# SM-ChiP™

## Reflow Soldering Recommendations



Contents	Page
<a href="#">Introduction</a>	<a href="#">1</a>
<a href="#">SM-ChiP Package Description</a>	<a href="#">1</a>
<a href="#">MSL Handling and Storage</a>	<a href="#">2</a>
<a href="#">Solder Process Design</a>	<a href="#">2</a>
<a href="#">Chemistry and Alloy</a>	<a href="#">2</a>
<a href="#">Solder Paste Stencil Design</a>	<a href="#">2</a>
<a href="#">Stencil Aperture Recommendations</a>	<a href="#">3</a>
<a href="#">Screenprinting</a>	<a href="#">3</a>
<a href="#">Pick and Place</a>	<a href="#">4</a>
<a href="#">Oven Reflow Profile Recommendations</a>	<a href="#">5</a>
<a href="#">Oven Reflow Profile Diagram</a>	<a href="#">5</a>
<a href="#">Post-Reflow Process</a>	<a href="#">6</a>
<a href="#">Cleaning</a>	<a href="#">6</a>
<a href="#">Inspection</a>	<a href="#">6</a>
<a href="#">SM-ChiP Rework</a>	<a href="#">6</a>
<a href="#">Removal and Replacement</a>	<a href="#">7</a>
<a href="#">Conclusion</a>	<a href="#">7</a>
<a href="#">Appendix: Reflow Soldering Checklist</a>	<a href="#">8</a>



### Introduction

Vicor SM-ChiP products are intended for reflow soldering assembly. The information contained in this document defines the handling procedures and assembly processing conditions for successful attachment to a printed circuit board. Failure to follow these recommendations may result in aesthetic defects, device failure or reduced reliability due to compromised solder joint integrity.

### SM-ChiP Package Description

The SM-ChiP is a plated, overmolded Converter housed in Package platform intended for surface-mount attachment to a printed circuit board. Electrical and thermal connections are formed through soldered connections to plated castellation terminal features along the perimeter of the module and continuous plated surfaces of the main package body, where applicable.

- Refer to the package drawing provided in the product data sheet.
- Recommended footprint is specified in the package drawing.
- Plated surface finish is specified in the product data sheet.
- Unless otherwise specified in the product data sheet, SM-ChiPs are MSL 4 and qualified for a maximum of three reflow cycles.

---

## MSL Handling and Storage

- SM-ChiP™ components are baked and dry-packed prior to shipment.
- Components should remain in a dry vacuum bag during storage prior to assembly.
- An MSL label is attached to the outside bag indicating maximum open air exposure and bake times.
- Within the bag is a humidity indicator card and desiccant pack.

Exposure to ambient humidity for periods longer than those specified on the Moisture-Sensitive Caution label will require the component be baked at 125°C to remove absorbed moisture. Baking must be performed in a convection oven with either nitrogen or dry air purge for at least 96 hours prior to assembly. SM-ChiP components may be baked multiple times to remove moisture absorbed during on-floor manufacturing conditions. If dry air purge is used in the convection oven it is recommended that maximum bake temperature be set at 125°C.

Moisture uptake by the component is cumulative with exposure time to ambient humidity conditions between reflow cycles. If a component will be exposed to reflow soldering multiple times during assembly, care must be taken to ensure that the total exposure time to ambient conditions does not exceed the MSL rating of the device.

MSL and reflow temperatures may vary by product. Please refer to the specific product datasheet for the appropriate MSL and reflow rating for the SM-ChiP product being handled. Failure to follow the MSL handling listed on the datasheet or the bake procedure may result in damage to the component package during the initial or subsequent reflow procedures. This damage could include package blistering, delamination, or internal solder shorting resulting in loss of electrical functionality or reduced operating life. The damage incurred may not be visible by inspection of the external package. In addition to observing proper MSL handling of the SM-ChiP, the target PCB onto which the SM-ChiP is soldered should observe appropriate MSL handling prior to SMT processing.

## Solder Process Design

### Chemistry and Alloy

SM-ChiP components are compatible with tin-lead and lead-free solder alloys as well as water-soluble and no-clean flux chemistries. Specific application requirements may dictate the choice of solder alloy and flux chemistry.

### Solder Paste Stencil Design

- Stencil material: fine-grain stainless steel
- Thickness: 4 – 7mils
- Cut process: laser cut
- Coating: nano-coating recommended to improve solder paste release and print uniformity

**Figure 1**  
Detail of stencil apertures  
over PCB pads

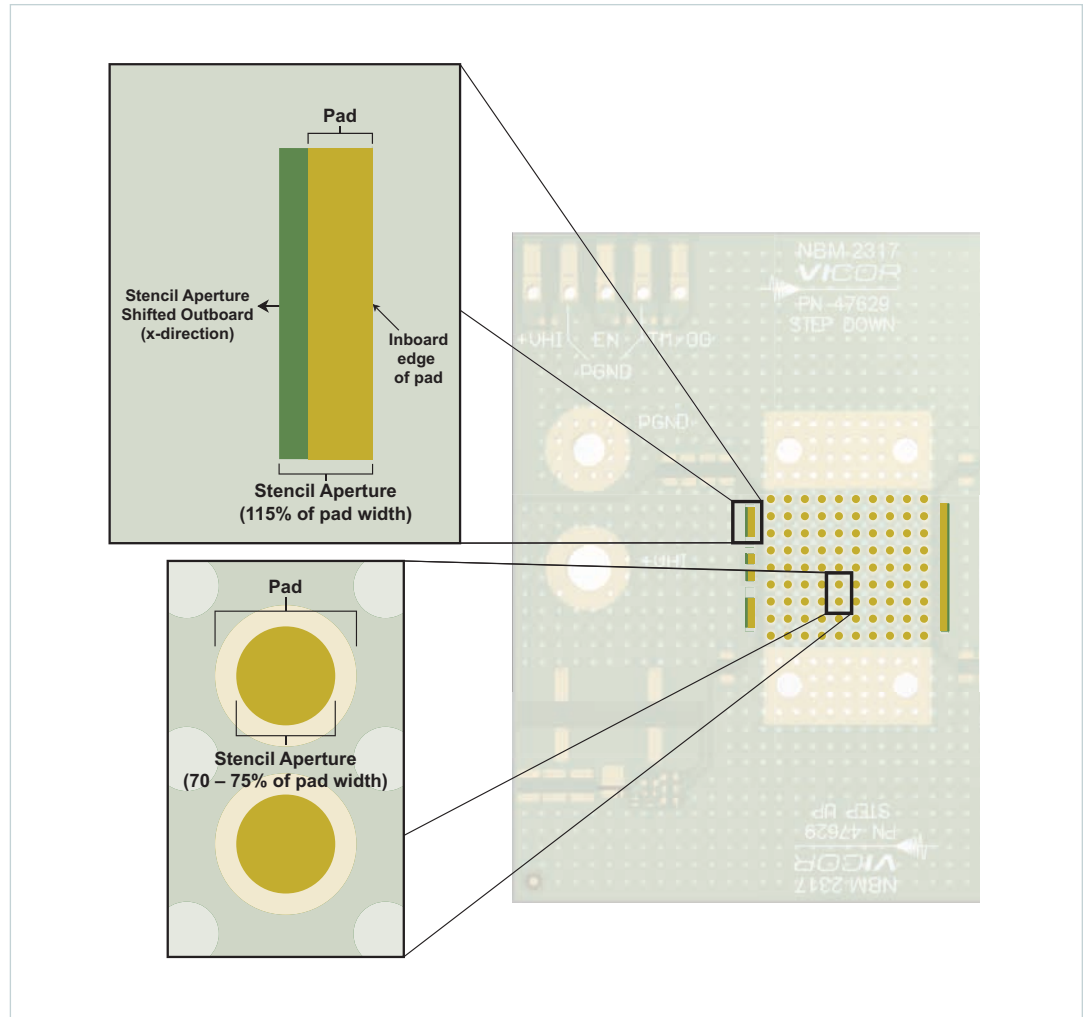

### Stencil Aperture Recommendations

Figure 1 illustrates the recommendations for SM-ChiP stencil apertures. In general when using a 4mil thick stencil, overprint of the PCB pad is recommended to support proper fillet formation. Castellation apertures should be 115% of pad width (x-direction) and 100% of pad length (y-direction). The stencil aperture should be offset to line up with the inboard edge of the PCB pad.

PGND pad stencil apertures beneath the main body of the component should be reduced to 70 – 75% of the pad diameter.

Depending on the application, the addition of solder preforms may be necessary to achieve acceptable fillet formation. For stencils thicker than 4mils, the aperture overprint may be reduced and preforms may no longer be necessary.

### Screenprinting

During screen printing, care should be taken to ensure that residual solder paste on the bottom of the stencil is not being transferred from board to board. If necessary, establish a cleaning process for the stencil after each PCB is processed.

## Pick and Place

All personnel and equipment handling SM-ChiP™ components should have proper ESD protection to avoid damaging the units during the mounting process.

Pick and place of SM-ChiP components should be made from the center of the package. SM-ChiP components should be optically centered using the castellated terminations. Mechanical centering or optical corner centering should not be employed. Due to the large surface area of SM-ChiP components, a pick-and-place z-axis pressure of 150 – 500g and dwell time after placement of between 0.5 – 1s is recommended to achieve proper seating in the solder paste deposits and adequate wetting during reflow. After initial pick-and-place settings are created, inspect the first piece for alignment accuracy and ensure that all solder connections are resting in solder paste prior to reflow.

Staking adhesive, such as LOCTITE® 3621, may be required dependent upon package size and whether the package will be subjected to multiple reflows as part of a multi-sided assembly. A recommended dispense pattern is illustrated in Figure 2 on an example SM-ChiP component footprint. Solder paste stencil apertures at the four indicated corner PGND solder pads are omitted. Adhesive is dispensed in these locations onto the PCB after solder paste application and prior to SM-ChiP placement.

**Figure 2**  
Detail of staking adhesive pattern and modified solder paste stencil for example MCD3509 application

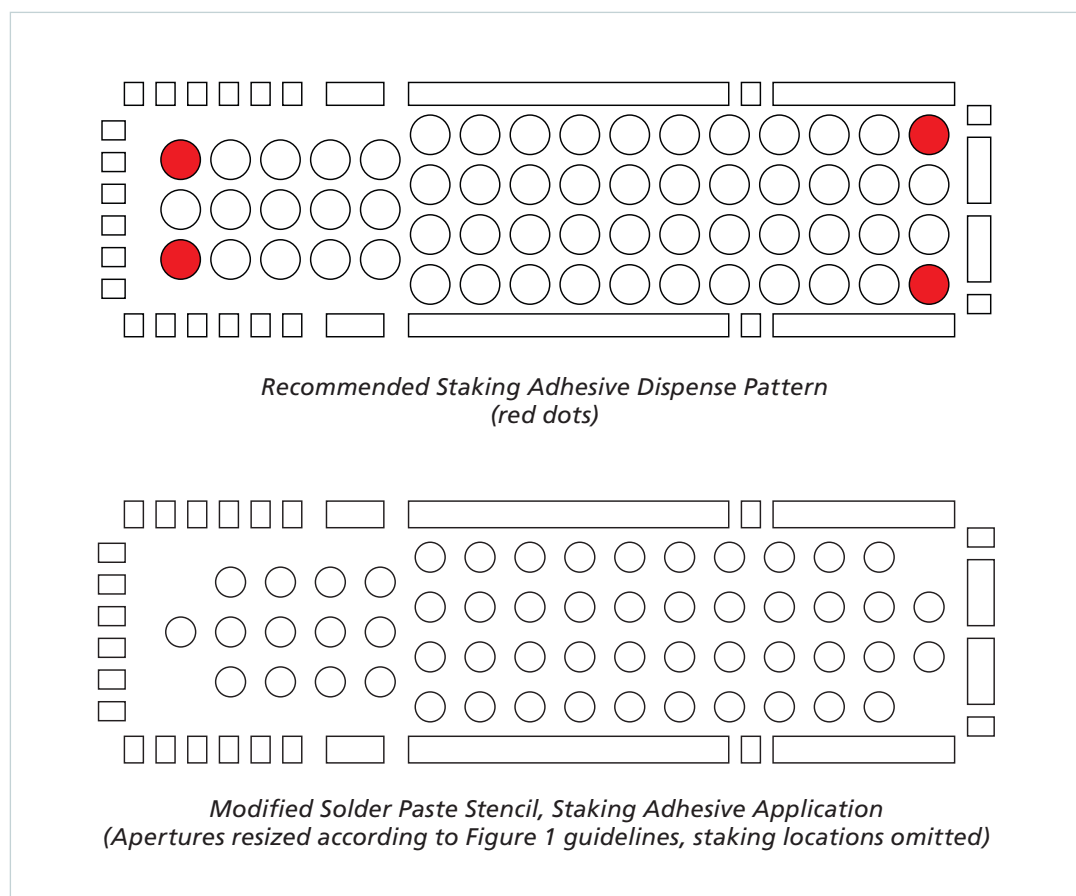

## Oven Reflow Profile Recommendations

A forced-air convection oven is recommended for reflow attachment of SM-ChiP modules. Other types of reflow methods (Vapor Phase, IR, etc.) have not been qualified or approved for use with SM-ChiP components.

The optimal reflow profile for the SM-ChiP is dependent upon PCB layout and construction. Attach thermocouples to the top of the case of the SM-ChiP module and to one or more terminations. Large packages may have a temperature gradient of no more than 10°C from leading to trailing edge. Careful monitoring is required to ensure that the entire package temperature stays within the appropriate range.

The optimal oven profile will ramp to spike with the following characteristics:

- Time above liquidus ( $t_L$ ): 30 – 90 seconds, ideal 60 seconds
- Peak temperature of terminations: 235 – 245°C, ideal 240°C
- Case temperature shall not exceed 245°C

Dependent upon board layout and construction, a slower belt speed and ramp-soak-spike profile may be necessary in order to uniformly heat the SM-ChiP module and PCB to the same temperature. Ramp to spike profiles may not adequately deliver heat to the SM-ChiP module while also overheating other components of the board assembly.

## Oven Reflow Profile Diagram

The following reflow parameters and profile in Table 1 and Figure 2 are provided as an example only. Actual reflow parameters and profile configuration may vary depending on the customer equipment and capabilities.

All temperatures in Table 1 refer to the topside of the package, measured at the center of the package on the body's surface.

**Table 1**  
Reflow profile  
recommendations  
adapted from  
JEDEC/IPC J-STD-020E.1

Reflow Profile Feature	Sn-Pb Eutectic Assembly	Pb-Free Assembly
Preheat temperature minimum ( $T_{SMIN}$ )	100°C	150°C
Preheat temperature maximum ( $T_{SMAX}$ )	150°C	200°C
Preheat time ( $t_s$ ), from $T_{SMIN}$ to $T_{SMAX}$	60 – 120 seconds	60 – 120 seconds
Liquidus temperature ( $T_L$ )	183°C	217°C
Ramp-up rate from $T_L$ to $T_p$	3°C/s, maximum	3°C/s, maximum
Time ( $t_L$ ) above liquidus temperature ( $T_L$ )	30 – 90 seconds; ideal 60 seconds	30 – 90 seconds; ideal 60 seconds
Peak package body temperature ( $T_p$ )	220°C	245°C
Time ( $t_p$ ) within 5°C of peak temperature ( $T_p$ )	20 seconds	20 seconds
Ramp-down rate ( $T_p$ to $T_L$ )	6°C/s, maximum	6°C/s, maximum
Time 25°C to peak temperature ( $T_p$ )	6 minutes, maximum	8 minutes, maximum

**Figure 3**  
Standard graph of critical  
reflow parameters adapted  
from JEDEC/IPC J-STD-020E.1

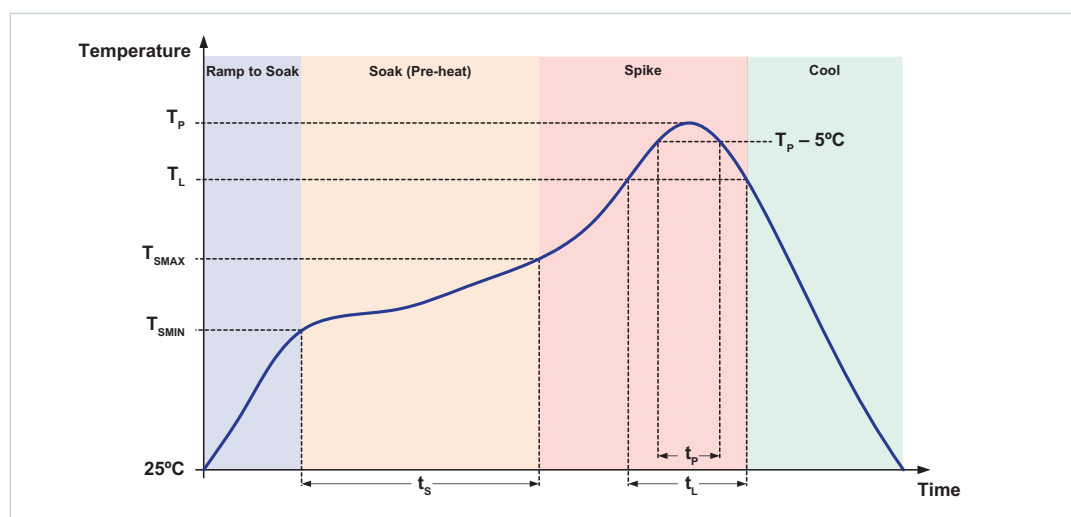

---

## Post-Reflow Process

### Cleaning

Cleaning requirements following reflow are dependent upon the flux chemistry used in processing. In general, it is recommended that flux residue be removed from the soldered surfaces of the SM-ChiP™ package and surrounding PCB area. Otherwise, this residue could become electrically conductive and cause failures over time. Even “no-clean” flux residue can be harmful in terms of electromigration and THB performance failures. In applications where flux will not be cleaned, reliability tests are recommended to ensure long-term reliability is not compromised.

SM-ChiP modules are compatible with standard water-wash procedures for removal of water-soluble flux chemistries. Use of a saponifier or ultrasonic deionized water spray is recommended. If the SM-ChiP module must be subjected to additional reflow cycles after water washing, it must first be baked to eliminate moisture. See MSL Handling and Storage section.

### Inspection

SM-ChiP modules should generally be inspected to the criteria outlined in the latest revision of the IPC-A-610 standard, with solder joints classified as Castellated Terminations. Solder fillet must be present as evidence of a wetted castellated termination. X-ray inspection is recommended for solder pad connections beneath the main body of the package.

### SM-ChiP Rework

If a component adjacent to the SM-ChiP must be removed or reworked, the temperature of the SM-ChiP module must be kept below 140°C during that rework procedure. If this is not possible, the entire printed circuit board assembly must be baked according to the MSL Handling and Storage Guidelines prior to commencing rework on neighboring components.

SM-ChiP modules cannot be reused after removal from a printed circuit board. If an SM-ChiP module must be removed and replaced due to an assembly defect, module failure or other reason, it is important to consider the following:

- The reason for module removal should be known and well understood. There are numerous avenues that should be investigated prior to removing and replacing the SM-ChiP module on the assembly. For example: if the application is suspect, a review of the operating conditions and performance requirements should be initiated before replacement to prevent a recurring failure.
- If a failure investigation is required, special care must be taken when removing the SM-ChiP module to preserve the failure site within the module for analysis. The ideal way to preserve the failure site is to submit the entire printed circuit board assembly with the SM-ChiP module intact to Vicor for failure analysis. Please note that the customer PCB will be destroyed in the process of analyzing the module failure. If this is not feasible, proceed with following removal procedure and take special care to not exceed the maximum SM-ChiP case temperature of 245°C.

---

## Removal and Replacement

Use of a dedicated surface-mount component rework station is highly recommended. Usage of hand tools such as a soldering iron or hot air pencil may cause damage to the SM-ChiP module or underlying PCB assembly due to uneven or excessive heating. Contact Vicor Applications for recommendations on suitable rework equipment. In general, an appropriate rework station will have the following features:

- PCB support fixture with x- and y-axis positioning
- Bottom-side PCB heating element (e.g., IR or convection) with temperature control
- Top-side PCB hot air heating nozzle with adjustable aperture size and temperature control
- Vacuum nozzle for component removal
- Magnification or optical inspection apparatus for tool alignment and monitoring the removal process

### *Procedure for removal of an SM-ChiP module*

1. Bake the printed circuit board assembly with SM-ChiP module according to MSL handling and storage guidelines prior to removal process.
2. Create a reflow profile based on the solder alloy used when the SM-ChiP was installed. This profile should mimic a typical oven reflow profile. Refer to oven reflow profile diagram for recommended process parameters for both Sn-Pb Eutectic and Pb-Free assemblies. Fit an appropriately sized nozzle to focus the hot air flow on the SM-ChiP module. During removal, the top case temperature of the SM-ChiP module should be monitored to not exceed the specified peak package body temperature TP.
3. Ensure the correct vacuum tip size is installed such that the module can be pulled away from the assembly when the solder is molten.
4. If staking adhesive was originally used when mounting the SM-ChiP to a PCB, additional steps may need to be taken prior to removal of the SM-ChiP to weaken or break the adhesive bond. Consult the adhesive manufacturer for any recommendations or precautions.
5. Prepare the site with liquid flux (no-clean or water soluble) to ease the removal process.
6. Start the removal process. Heat the SM-ChiP module and solder connections using the previously developed rework station reflow profile. Monitor the solder along the module castellations for phase transition from solid to liquid. Lift the module away from PCB using the vacuum nozzle when the solder is molten.

### *Procedure for replacement of an SM-ChiP module*

1. Prepare the site to accept a replacement module. Residual solder must be removed or wicked away from all pads of the component footprint to create a smooth surface. Any remaining flux residue from the removal process must also be cleaned.
2. Apply solder paste compatible with the rework station reflow profile developed for the removal process. A miniature solder-stencil screen is recommended for paste application.
3. Place a new SM-ChiP component either manually or, if the rework station is so equipped, with an automatic pick-and-place arm.
4. Reflow the replacement component onto the PCB using the same profile used during the removal process. Observe and inspect all solder joints during reflow to verify solder liquidus transition.
5. Following reflow of the replacement component, clean and inspect site in accordance with recommendations provided in post-reflow process.

## Conclusion

This document provides guidelines for proper MSL handling, reflow and post-processing procedures of Vicor SM-ChiP modules. While every design and manufacturing process is unique, adherence to the presented recommendations when attaching SM-ChiP modules to printed circuit boards will minimize the risk of poor solder joint integrity and associated reduced reliability and device failure due to improper processing techniques.

## Appendix: Reflow Soldering Checklist

Determining the cause of reflow soldering defects can be a challenging process given the myriad of environmental, handling, and process parameters that influence the overall quality of the produced solder joints. The following is an inclusive but not an exhaustive list of questions and considerations to aid in reviewing an SM-ChiP™ reflow process that does not meet quality expectations or requirements.

Process Parameter	Consideration
SM-ChiPs and Printed Circuit Boards	Is the time out of the bag within the MSL specifications supplied by the manufacturer?
	Are all reflows completed before the cumulative ambient exposure time is reached? Consider storage of incomplete assemblies and manufacturing down-time between subsequent reflows.
	Are the SM-ChiPs and PCBs being delivered to the manufacturing floor in sealed moisture barrier bags with desiccant and a humidity indicator card (HIC)?
	Does the color indicated by the HIC require that the boards/components be baked prior to assembly?
	Are operators observing all handling precautions including the wearing of gloves to prevent transfer of finger oils or other foreign debris to solder pad surfaces?
Manufacturing Environment	Maintain a record of manufacturing environment humidity and temperature. These records may be used as a point of comparison should reflow soldering defects develop suddenly.
	The factory environment should be well-controlled, with an ambient temperature between 21 and 25°C and relative humidity in the range of 35 – 65%. Temperature and humidity outside of these ranges can result in a variety of soldering issues and defects such as insufficient solder joints, solder balling, poor printing, smearing, slumping, excessive outgassing or voiding.
Solder Paste	How long has the solder paste been out of refrigeration and exposed to the ambient manufacturing environment? Is this time within the paste manufacturer's specifications?
	How long has the solder paste been on the stencil during/between production runs? Excess time on the stencil can lead to degradation and evaporation of the flux.
	Keep track of the solder paste lot code for reference purposes in the event of a sudden appearance of reflow defects.
Screen Printing	Verify stencil underside cleaning process is functioning correctly. Residual paste and flux left over from inadequate cleaning will transfer to the next printed PCB and may generate solder balls after reflow.
	Is a nano-coating being used to improve paste release and print uniformity?
	Does the stencil display signs of excessive wear and require replacement?
	Review stencil design parameters: material, thickness, aperture dimensions.
Pick and Place	Review SM-ChiP placement accuracy. Inspect for accurate location and any rotation or tilt relative to the PCB. Verify SM-ChiP top/bottom orientation.
	Is the placement force and dwell time adequate to ensure the SM-ChiP settles evenly into paste?
	Is staking adhesive needed to prevent SM-ChiP movement (multi-sided assemblies)?
Oven Reflow	Review oven profile with a test board outfitted with thermocouples. Note that a profile developed on one oven will not directly transfer to another. Each oven used for production must be characterized with a test board to develop the optimal profile.
	Review consistency of profile using test board outfitted with thermocouples. Perform multiple passes to verify consistency and make adjustments if necessary.
	Is the PCB mounted within a fixture or pallet during reflow? Does the fixture dimensionally constrain the PCB, causing it to warp during reflow?
	Is the oven environment air only or nitrogen? An inert nitrogen environment may aid with reducing reflow pad and terminal oxidation during reflow.



---

## Revision History

Revision	Date	Description	Page Number(s)
1.0	07/26/19	Initial release	n/a
1.1	05/01/20	Updated SM-ChiP™ package description Expanded soldering rework section	1 6, 7
1.2	06/19/20	Updated pick and place centering Updated post-reflow inspection	4 6
1.3	04/05/22	Updated MSL handling and storage	2
1.4	12/02/24	Updated MSL handling and storage	2

---

## Limitation of Warranties

Information in this document is believed to be accurate and reliable. HOWEVER, THIS INFORMATION IS PROVIDED "AS IS" AND WITHOUT ANY WARRANTIES, EXPRESSED OR IMPLIED, AS TO THE ACCURACY OR COMPLETENESS OF SUCH INFORMATION. VICOR SHALL HAVE NO LIABILITY FOR THE CONSEQUENCES OF USE OF SUCH INFORMATION. IN NO EVENT SHALL VICOR BE LIABLE FOR ANY INDIRECT, INCIDENTAL, PUNITIVE, SPECIAL OR CONSEQUENTIAL DAMAGES (INCLUDING, WITHOUT LIMITATION, LOST PROFITS OR SAVINGS, BUSINESS INTERRUPTION, COSTS RELATED TO THE REMOVAL OR REPLACEMENT OF ANY PRODUCTS OR REWORK CHARGES).

Vicor reserves the right to make changes to information published in this document, at any time and without notice. You should verify that this document and information is current. This document supersedes and replaces all prior versions of this publication.

All guidance and content herein are for illustrative purposes only. Vicor makes no representation or warranty that the products and/or services described herein will be suitable for the specified use without further testing or modification. You are responsible for the design and operation of your applications and products using Vicor products, and Vicor accepts no liability for any assistance with applications or customer product design. It is your sole responsibility to determine whether the Vicor product is suitable and fit for your applications and products, and to implement adequate design, testing and operating safeguards for your planned application(s) and use(s).

VICOR PRODUCTS ARE NOT DESIGNED, AUTHORIZED OR WARRANTED FOR USE IN LIFE SUPPORT, LIFE-CRITICAL OR SAFETY-CRITICAL SYSTEMS OR EQUIPMENT. VICOR PRODUCTS ARE NOT CERTIFIED TO MEET ISO 13485 FOR USE IN MEDICAL EQUIPMENT NOR ISO/TS16949 FOR USE IN AUTOMOTIVE APPLICATIONS OR OTHER SIMILAR MEDICAL AND AUTOMOTIVE STANDARDS. VICOR DISCLAIMS ANY AND ALL LIABILITY FOR INCLUSION AND/OR USE OF VICOR PRODUCTS IN SUCH EQUIPMENT OR APPLICATIONS AND THEREFORE SUCH INCLUSION AND/OR USE IS AT YOUR OWN RISK.

## Terms of Sale

The purchase and sale of Vicor products is subject to the Vicor Corporation Terms and Conditions of Sale which are available at: (<https://www.vicorpower.com/termsconditionswarranty>)

## Export Control

This document as well as the item(s) described herein may be subject to export control regulations. Export may require a prior authorization from U.S. export authorities.

Contact Us: <https://www.vicorpower.com/contact-us>

**Vicor Corporation**  
25 Frontage Road  
Andover, MA, USA 01810  
Tel: 800-735-6200  
Fax: 978-475-6715  
[www.vicorpower.com](http://www.vicorpower.com)

### email

Customer Service: [custserv@vicorpower.com](mailto:custserv@vicorpower.com)  
Technical Support: [apps@vicorpower.com](mailto:apps@vicorpower.com)