

Designing High-Power Arrays Using Maxi, Mini and Micro Family DC-DC Converters



Contents	Page
Introduction	1
PR Bus Architecture	1
Distribution Across Multiple Boards	1
Buffering	1
Bypassing	2
5kW, 1,000 Amp Example Array	2
Initial System Testing	5
Summary	10

Introduction

Vicor's Maxi, Mini and Micro DC-DC converters are designed for easy paralleling to increase output power. The unique paralleling interface allows multi-kW capable designs to be implemented with few external components. For information on paralleling up to 12 modules, see the Application Note: [Converter PR Pin Facilitates Parallel Operation for Power Expansion or Redundancy](#). For very high-power arrays of more than 12 modules, buffering of the PR signal is required as the fan-out limit of the communication bus is reached. This note describes how to use buffering to increase the capability of the bus to drive large numbers of converters, and gives an example of how to quickly prototype a multi-kW system. This allows the benefits of the Maxi, Mini and Micro family to be applied for systems with output power into the multi-kW range.

PR Bus Architecture

Parent / Child Configurations

One of the first decisions that must be made when designing large arrays is to define the number of parent modules. Large numbers of possible parents will increase redundancy but complicate PR and +S/-S line busing. Initially it may be tempting to configure all modules in a democratic array, but this may become cumbersome for arrays of greater than three modules. For large arrays a better choice is to define up to three modules as parents and add additional children for more power. This provides adequate redundancy for most applications.

Distribution Across Multiple Boards

It is often necessary to break an array of converters into multiple PC boards due to space and thermal requirements. Separation between boards will introduce additional impedance between the converters because of added lead/trace length. To keep interconnect impedance between boards from corrupting the control signals, Vicor's PR isolation transformer (Vicor P/N 29768) must be used to isolate the PR bus. It is recommended that all parents be located on the same board. This keeps noise and line delay between the parents to a minimum. This is especially important for very large arrays that will be subject to high dI/dt s and dV/dt s. If an application requires redundancy between boards or between more than twelve modules, a bidirectional buffer must be implemented. This is beyond the scope of this note.

The PR signal should be bussed between boards with a relatively lossy low-inductance connection. Twisted pair works well while coaxial cable is not appropriate. Reflections caused by the mismatch of PR bus source, load, and cable impedance will not be damped by the low-loss coaxial cable and result in reduced quality of the PR pulse.

Buffering

High-speed buffering may be required with large arrays or if the distance between modules is greater than a few inches. This is because all modules, except the one that's talking, are in the listening mode. Each listener presents a load to the parent (talker) of approximately 500Ω shunted by 30pF; see Figure 1. Long leads for the interconnection introduce losses and parasitic reactance on the bus that can attenuate and distort the sync-pulse signal. The bandwidth of the bus must be at least 60 MHz.

Figure 1
PR Pin Equivalent Circuit

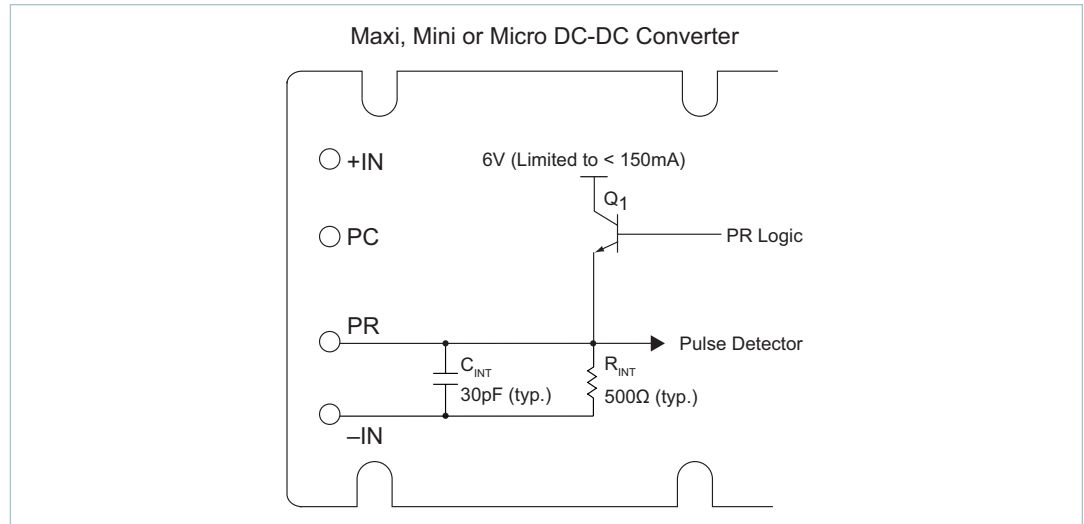

One simple and robust PR buffer scheme is shown in Figures 2 and 3. The system is separated into one parent board (Figure 2) and a number of child boards (Figure 3). The parent board consists of five modules. Two of these are configured in a democratic array with one trimmed down by 2% relative to the other. These modules drive two buffers. The first buffer (Q_2) drives three additional child modules on the parent board. The second drives the child boards. Each child board contains five modules that are configured as children by tying their SC pins to $-S$. There is a PR isolation transformer on each child board that isolates the incoming PR signal. This signal is then buffered and fed to each child module.

The buffers are basic emitter followers that use general-purpose NPN transistors. Transformers labeled T1 have 1:1 turns ratios and can be implemented by using Vicor's PR isolation transformer with one coil left open circuited. Transformers labeled T2 have turns ratios of 2:1 to give better matching to the PR distribution bus. The return path for each transformer or buffer must be Kelvin connected to the $-IN$ pin of the appropriate converter. An 8V auxiliary supply gives sufficient headroom for the followers. It is a low-power rail that can be derived from a higher voltage using a linear regulator. A separate auxiliary supply must be derived on each board so that PR bus isolation is maintained. The high frequency bypassing directly at each buffer is essential.

Because of the high speed of the PR signal careful attention must be paid to the signal fidelity of the PR bus. Locations for both series and shunt damping resistors should be included in the layout as shown in Figures 2 and 3. Populating all of these components may not be necessary for all arrays depending on the geometry of the PR bus. Both parent and child modules should have reverse-polarity protection diodes (D_1) on the PR pins.

Bypassing

Selection of bypassing components has important consequences for stability and EMI performance of high-power arrays. Common-mode bypassing for each converter should be implemented as shown in the [Maxi, Mini and Micro Design Guide and Applications Manual](#).

Differential-mode bypassing can be considered in two parts. Low-frequency bypassing that keeps source impedance low and stabilizes the converter's voltage loop and high-frequency bypassing that reduces switching related EMI. Low-frequency bypassing should be done according to the Design Guide. Array input impedance is the individual converter negative input impedance divided by the number of converters in the array. This can present a challenge for very large low-input-voltage arrays where impedances must be kept very low.

5kW, 1,000 Amp Example Array

The following prototype was implemented with modules placed on evaluation boards and connected as shown in Figures 2 and 3. It uses 25 modules with part number V300B5C200B operating in parallel. The array has a 300V input, 5V 1000A output, and is connected in a 5 x 5 array. Output leads must be very heavy gauge so as to have sufficient ampacity to safely carry the high output currents. To reduce the chance of noise causing the parents to swap control, R_5 is configured for 2% trim down. When using Micro family converters in parallel arrays it is imperative that the output voltage of each parent is trimmed a minimum of 2% apart.

Figure 2
 Prototype Array Parent Board,
 One Per System

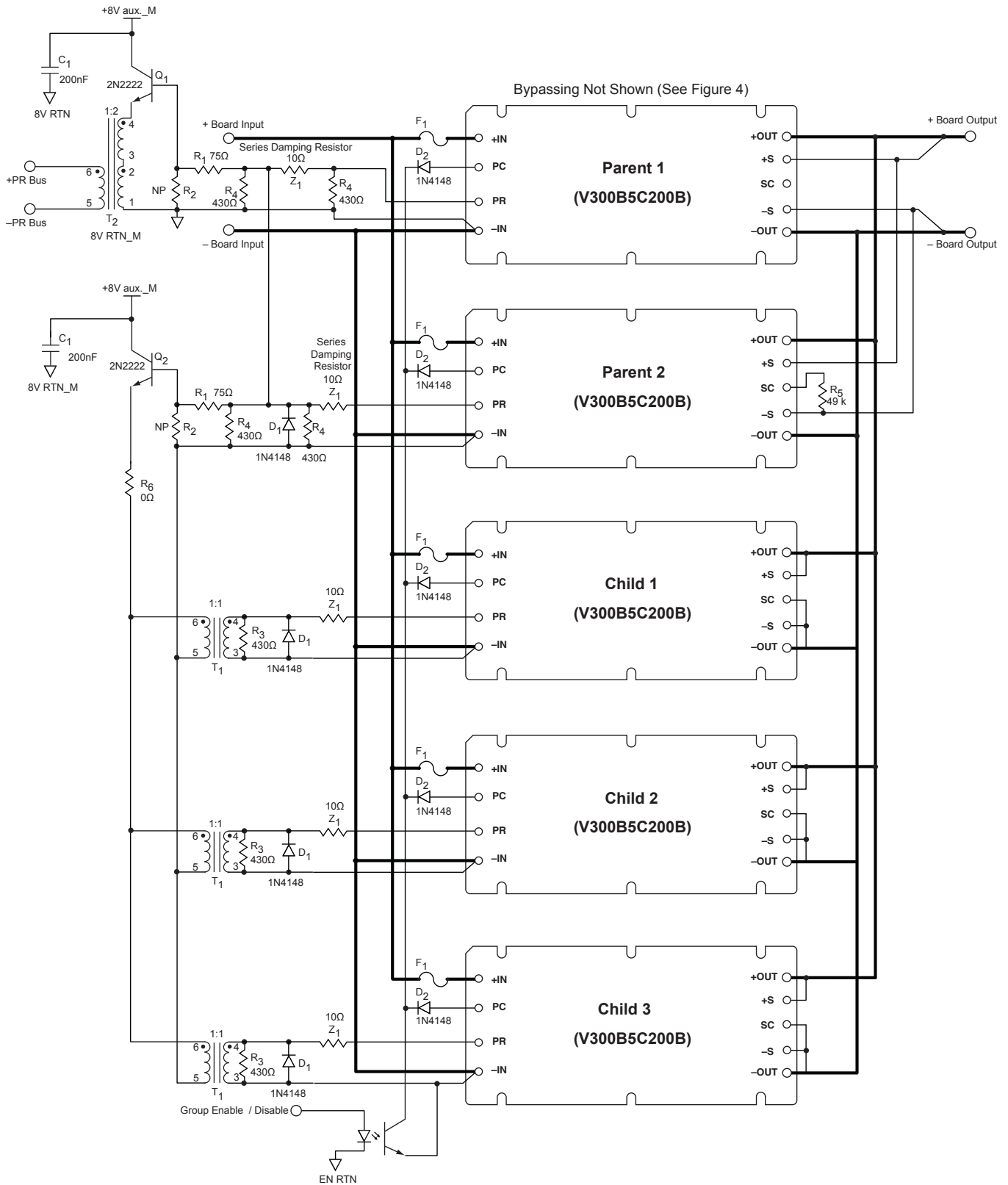

Figure 3

Prototype Array Child Board,
Four Per System

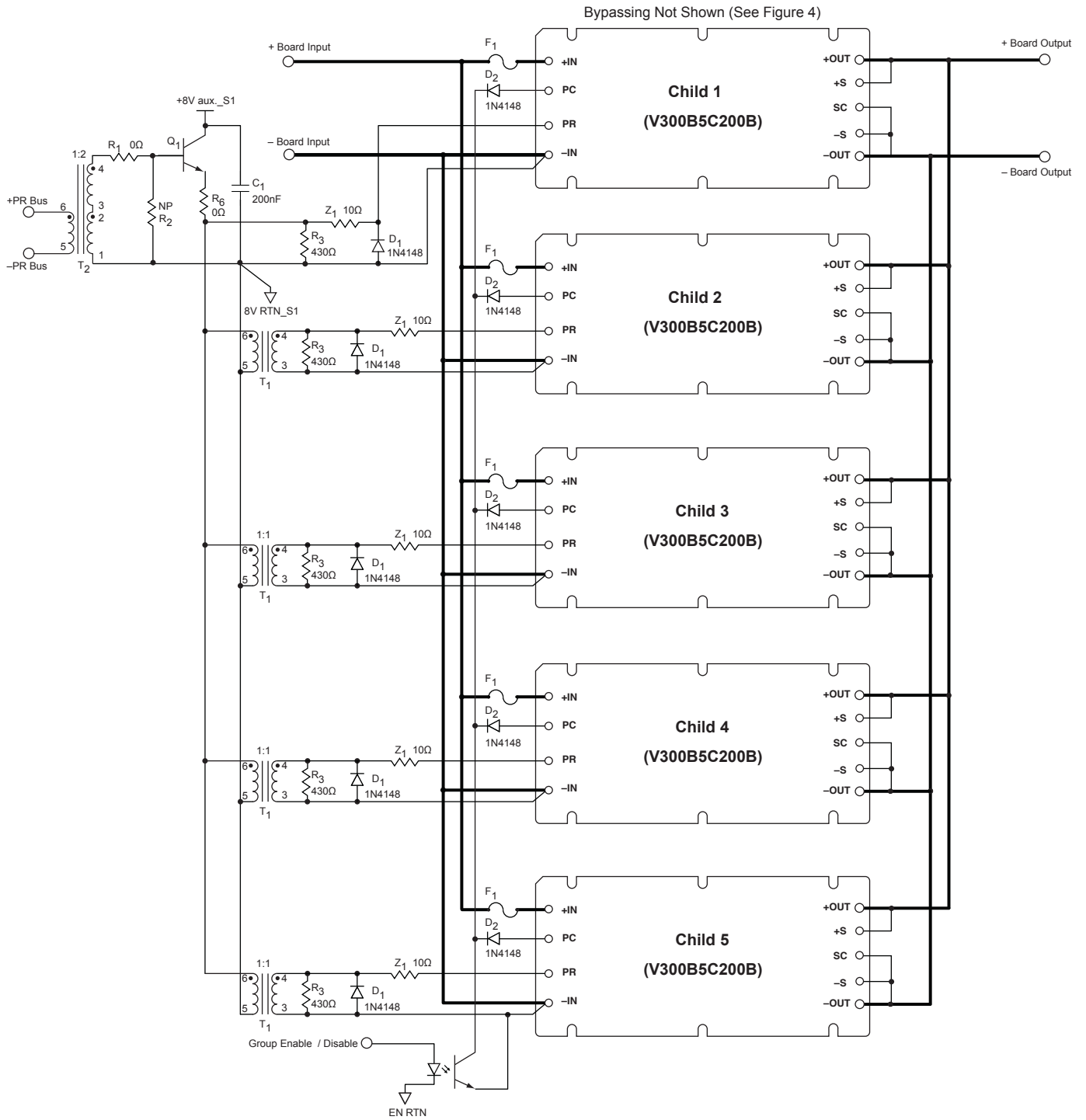
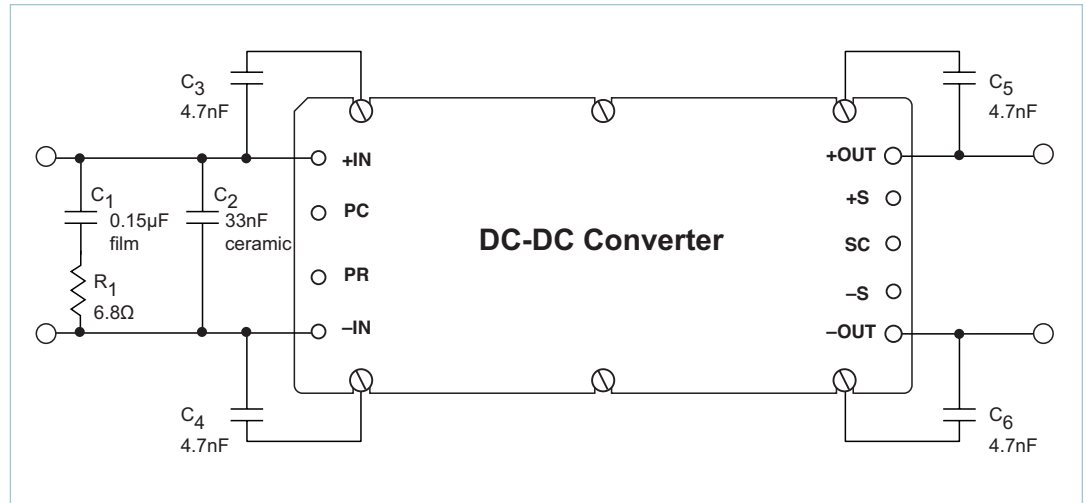

Figure 4
 Differential-Mode and
 Common-Mode Bypassing for
 5kW Array, Each Module



The PC pins of the converters have been diode OR'd to provide group enable / disable for the array. An external control circuit such as a microprocessor can provide this signal. At a minimum, group undervoltage / overvoltage lockout is required, see the Vicor application note: [Undervoltage / Overvoltage Lockout](#). Because of voltage drops between input leads of individual boards an optocoupler must be used to correctly drive the PC pins.

Differential and common-mode bypass capacitors were added close to each converter as shown in Figure 4. In addition, a 24μF capacitor in series with 6.8Ω damping resistor was added across the input of the entire array. See Page 7 for information on how these values were chosen.

Note: The high-power capability of the array's input source make proper safety precautions vital. Individual fusing is required for each converter as directed by the Design Guide and Applications Manual. If the array is supplied by an offline source an isolated scope should be used when making input side measurements. Never apply power to an array without connecting the output of the parent board and all child boards to the same point. Failure to do so will cause a destructive output overvoltage condition.

Initial System Testing

Even the best array design will not predict all parameters that will impact performance. Thorough testing during the prototyping phase is recommended so that optimal component values can be determined and potential issues avoided. Tests may include dynamic loading, checking input and output ripple, phase gain analysis, and PR bus signal fidelity. For safety and to simplify testing, initial power up should be performed on a subset of modules. For example, the parent board of the above array was tested first and the system was subsequently checked as each new child board was added.

PR Signal Fidelity

Optimal component values for damping the PR bus were found by testing the parent board and one child board (ten modules total). The PR bus should always be checked with an oscilloscope even if the array appears to behave properly.

Figure 5 shows the initial PR signal with series damping resistors (Z₁), and shunt damping (R₃, R₄) removed. This displays undesirable ring up due to parasitic L and C. This pulse violates the 7V absolute maximum rating on the PR pin. Insufficient damping may cause the pulse to make multiple transitions through the 2.5V latching threshold. This can cause extra power pulses to be generated and should be avoided to prevent module damage.

Figures 6 and 7 show the PR waveform on the primary parent and on the most distant child module after the damping is added. Both are examples of well-damped PR pulses. The damping values shown are good starting values for other array configurations.

The peak amplitude of the PR pulse should be at least 4V at every module for the pulse to be reliably detected, so more damping is not always better. The forward voltage drop associated with each emitter follower will add to PR signal attenuation.

Figure 5
PR Pin with Insufficient Damping,
Farthest from Parent

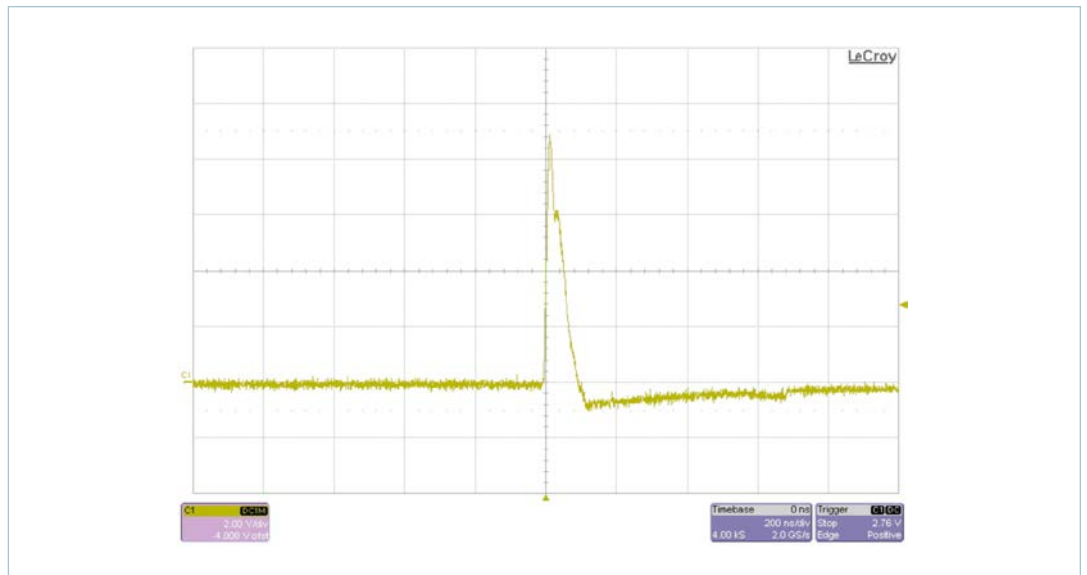

Figure 6
PR Pin, Primary Parent

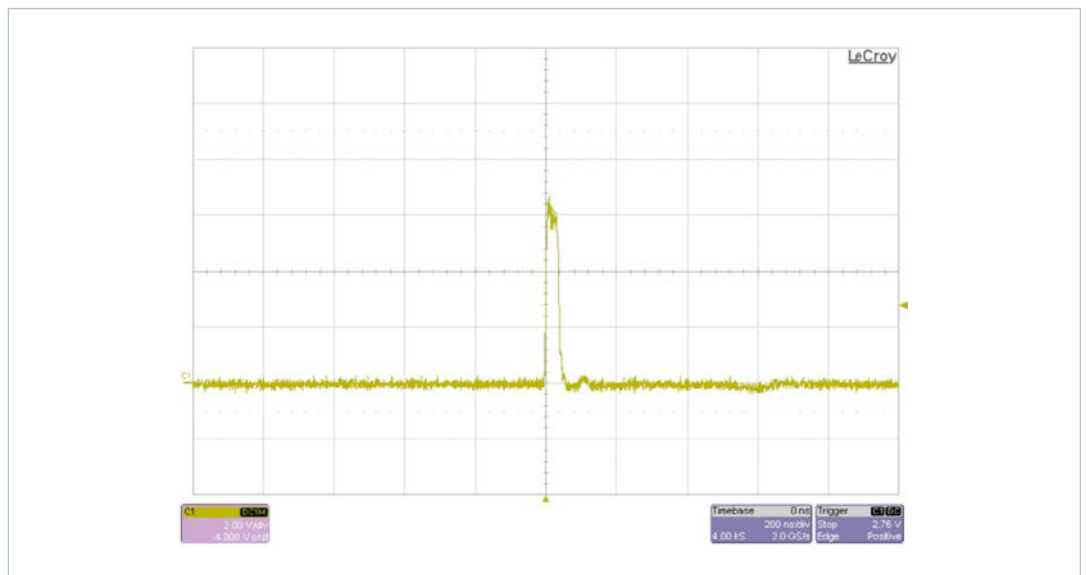

Figure 7
PR Pin, farthest from Parent

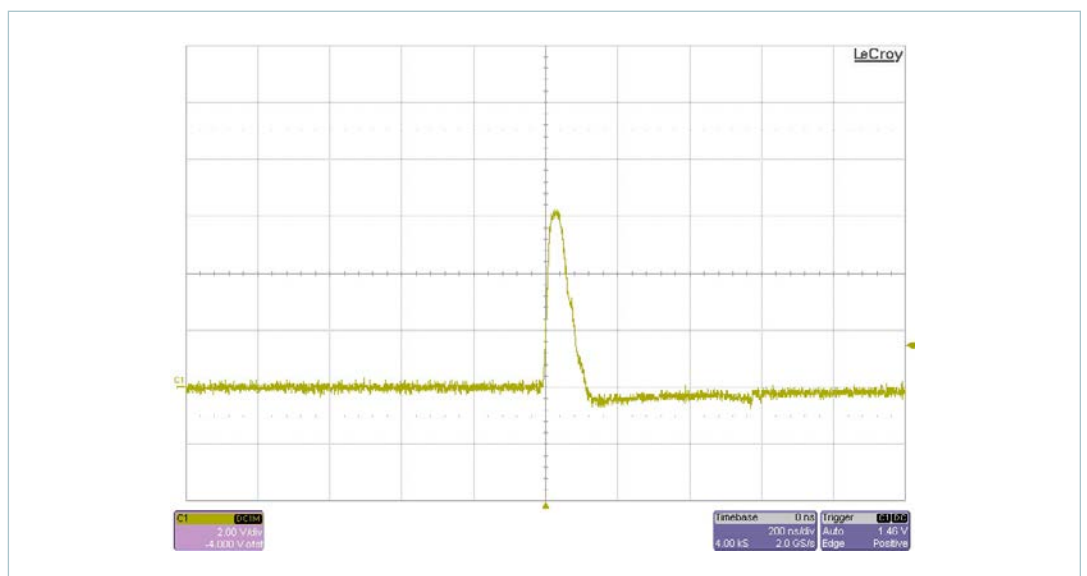

Figure 8
5kW Array Input, Full Load

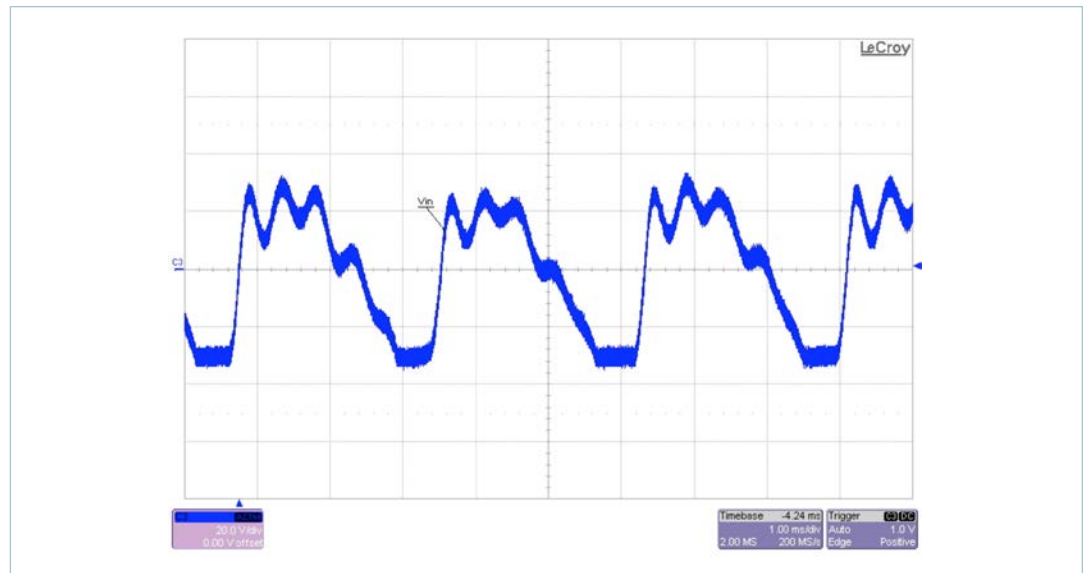
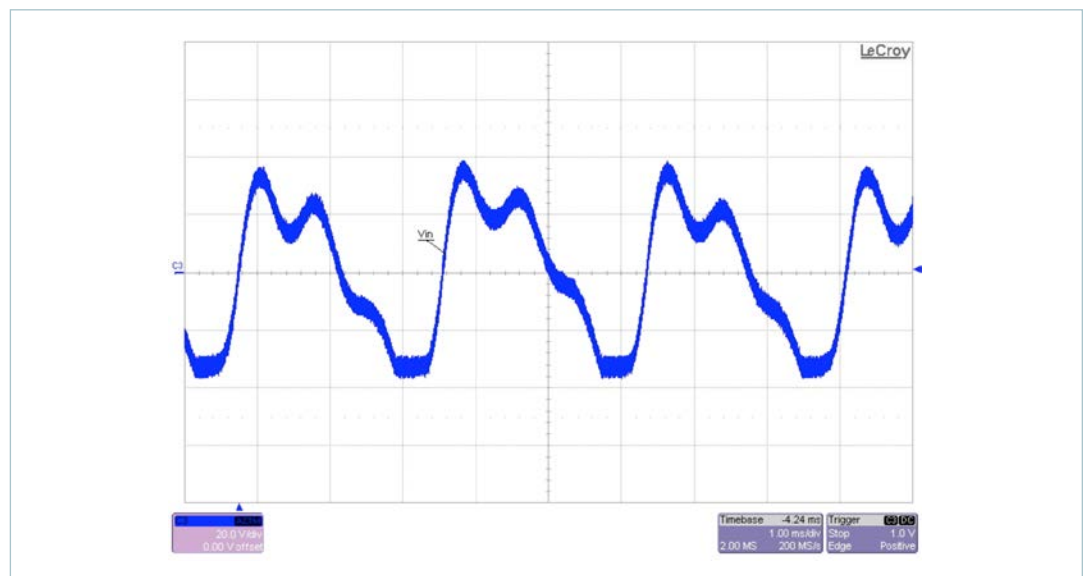

Figure 9
5kW Array Input, Full Load,
24 μ F Bypass



Input Ripple

For the 25 module prototype, using a high input voltage meant little low frequency bypassing was required. Input impedance was low since the array was supplied with short leads from Vicor's 5kW 3-Phase front end (Vicor P/N VI-TRY6-ICX). However, testing at full load uncovered a 2kHz oscillation on the DC input bus due to distribution inductance, see Figure 8. This high-frequency ring is undesirable and will increase the output ripple of the DC-DC converters. The 360Hz ripple is from the rectified 3-Phase 60Hz AC line.

To dampen this parasitic resonance, the following steps were taken. First the nominal line input impedance for this array was calculated:

$$Z_{IN} = \frac{(V_{NL})^2 \eta}{P_{converter} \cdot N} = \frac{(300V)^2 \cdot 0.82}{200W \cdot 25} = 14.8\Omega$$

Where:

V_{NL} is the nominal input voltage of the array

$P_{converter}$ is the output power of each converter

η is the minimum efficiency of the V300B5C200B modules

N is the number of modules in the array

Solving for a capacitor with roughly five to ten times lower impedance at 2kHz gives about 24 μ F.

Film or ceramic capacitors must be used due to the high peak-to-peak ripple voltage on the DC input bus. The lightly filtered bus has the advantage of keeping the power factor of the supply high and minimizing inrush current. Figure 9 shows the result of adding this capacitance across the input terminals of the array.

The original ringing is gone but the added capacitors have caused a lower frequency ring. This suggests series damping resistance to reduce the Q of the added capacitors. Adding about 10 Ω of damping in series with these capacitors results in the input waveform in Figure 10. This resistance was determined experimentally to give optimal damping for the capacitor value chosen.

Figure 10
5kW Array Input, Full Load,
24 μ F Bypass, 10 Ω Damping

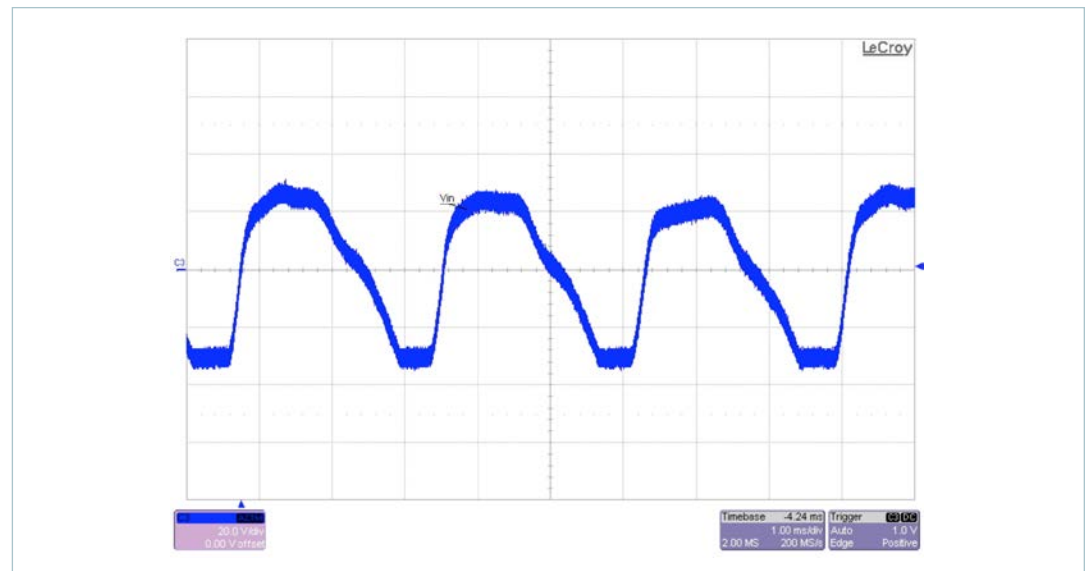

Figure 11
 Input Switching Noise with Two
 Modules No External Differential
 Bypass Capacitors

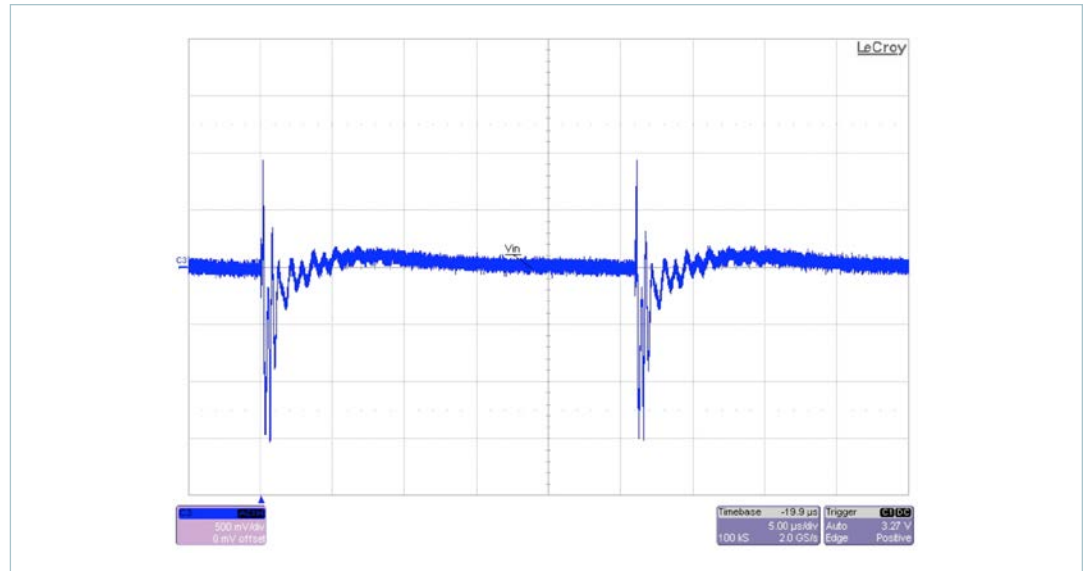
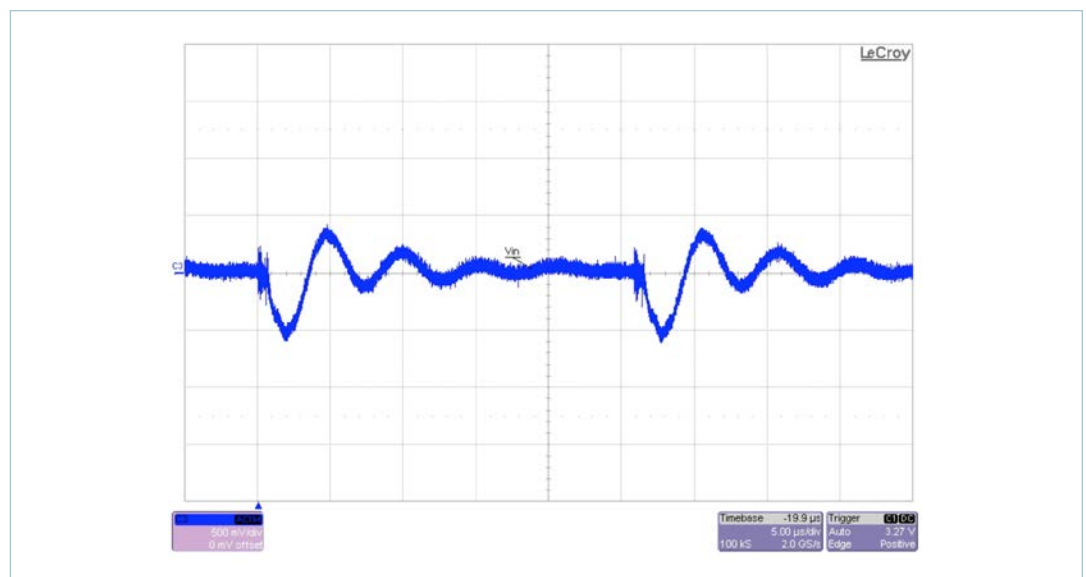

Figure 12
 Input Switching Noise with Two
 Modules with 0.15μF Film
 Differential Bypassing



EMI

High-frequency bypassing at the input of each module in the array can cut down on conducted noise before it can escape to the rest of the system, greatly reducing the demand for EMI filtering. Testing with several modules is the easiest method to arrive at optimal input bypassing. For example, Figure 11 shows the input waveform of two modules with no bypassing.

This waveform shows significant undesirable switching noise. To reduce it a 0.15μF film capacitor was added at the input of each module, Figure 4. The resulting waveform is shown in Figure 12. Film capacitors were used because of their moderate Q relative to ceramics.

Much of the high-frequency noise has been eliminated but the ringing is undesirable. Series damping was added to attenuate this ringing. A starting value for the damping resistor can be found by calculating the characteristic impedance of the 200kHz ring wave:

$$Z_{char} = \frac{1}{2\pi fC} = \frac{1}{2\pi (200kHz) 0.15\mu F} = 5.3\Omega$$

Based on this result a 6.8Ω damping resistor was added in series with the $0.15\mu\text{F}$ capacitor. This involved a tradeoff because the resistor reduces attenuation of the highest frequency components of switching noise. To regain low impedance bypassing at high frequency a 33 nF ceramic capacitor was added directly across the input of each converter, see Figure 4. This was chosen because it represents roughly one-fifth the value of the larger capacitor and can thus be neglected at low frequency. The effect of the final bypassing network is shown in Figure 13. More information on high frequency bypassing can be found in the Design Requirements section of the [Maxi, Mini and Micro Design Guide and Applications Manual](#).

Figure 13
Input Switching Noise with Two Modules with $0.15\mu\text{F}$ Film Differential Bypassing, 6.8Ω Series Damping Resistor, 33 nF Ceramic Differential Bypassing

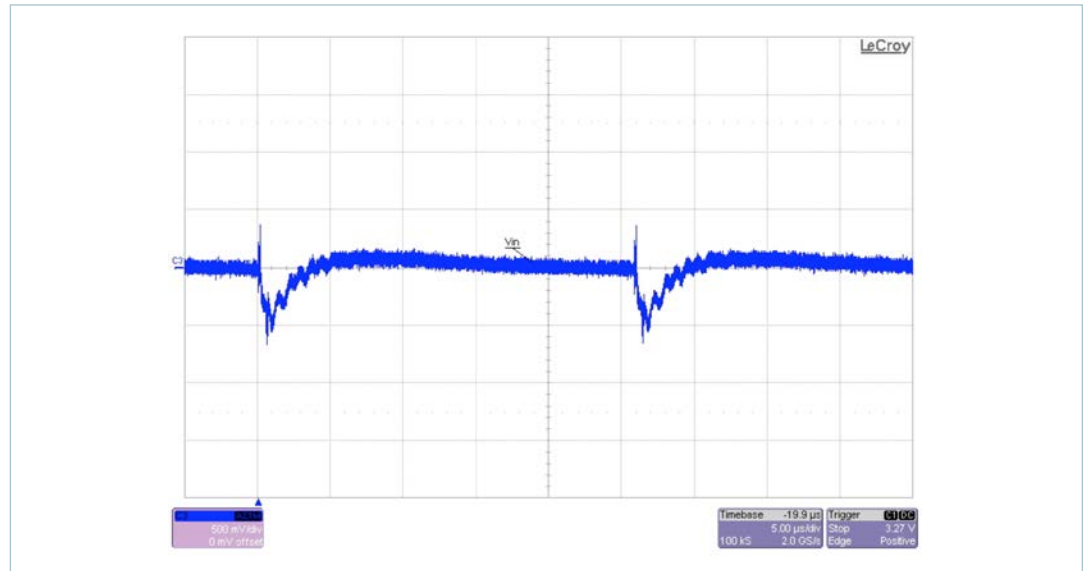

Summary

The techniques demonstrated in this example allow high power arrays using Maxi, Mini and Micro converters to be implemented with a minimum of design effort. With nominal input voltages from 24V to 375V and outputs from 2V to 52V this family of converters offer exceptional versatility, reliability and ease of use. Vicor's experienced technical support can assist you in applying the benefits of these converters to your high power application.

For more information, please contact Vicor's Applications Engineers at:

www.vicorpower.com/contact-us.

Limitation of Warranties

Information in this document is believed to be accurate and reliable. HOWEVER, THIS INFORMATION IS PROVIDED "AS IS" AND WITHOUT ANY WARRANTIES, EXPRESSED OR IMPLIED, AS TO THE ACCURACY OR COMPLETENESS OF SUCH INFORMATION. VICOR SHALL HAVE NO LIABILITY FOR THE CONSEQUENCES OF USE OF SUCH INFORMATION. IN NO EVENT SHALL VICOR BE LIABLE FOR ANY INDIRECT, INCIDENTAL, PUNITIVE, SPECIAL OR CONSEQUENTIAL DAMAGES (INCLUDING, WITHOUT LIMITATION, LOST PROFITS OR SAVINGS, BUSINESS INTERRUPTION, COSTS RELATED TO THE REMOVAL OR REPLACEMENT OF ANY PRODUCTS OR REWORK CHARGES).

Vicor reserves the right to make changes to information published in this document, at any time and without notice. You should verify that this document and information is current. This document supersedes and replaces all prior versions of this publication.

All guidance and content herein are for illustrative purposes only. Vicor makes no representation or warranty that the products and/or services described herein will be suitable for the specified use without further testing or modification. You are responsible for the design and operation of your applications and products using Vicor products, and Vicor accepts no liability for any assistance with applications or customer product design. It is your sole responsibility to determine whether the Vicor product is suitable and fit for your applications and products, and to implement adequate design, testing and operating safeguards for your planned application(s) and use(s).

VICOR PRODUCTS ARE NOT DESIGNED, AUTHORIZED OR WARRANTED FOR USE IN LIFE SUPPORT, LIFE-CRITICAL OR SAFETY-CRITICAL SYSTEMS OR EQUIPMENT. VICOR PRODUCTS ARE NOT CERTIFIED TO MEET ISO 13485 FOR USE IN MEDICAL EQUIPMENT NOR ISO/TS16949 FOR USE IN AUTOMOTIVE APPLICATIONS OR OTHER SIMILAR MEDICAL AND AUTOMOTIVE STANDARDS. VICOR DISCLAIMS ANY AND ALL LIABILITY FOR INCLUSION AND/OR USE OF VICOR PRODUCTS IN SUCH EQUIPMENT OR APPLICATIONS AND THEREFORE SUCH INCLUSION AND/OR USE IS AT YOUR OWN RISK.

Terms of Sale

The purchase and sale of Vicor products is subject to the Vicor Corporation Terms and Conditions of Sale which are available at: (<https://www.vicorpower.com/termsconditionswarranty>)

Export Control

This document as well as the item(s) described herein may be subject to export control regulations. Export may require a prior authorization from U.S. export authorities.

Contact Us: <https://www.vicorpower.com/contact-us>

Vicor Corporation

25 Frontage Road
Andover, MA, USA 01810
Tel: 800-735-6200
Fax: 978-475-6715
www.vicorpower.com

email

Customer Service: custserv@vicorpower.com
Technical Support: apps@vicorpower.com